

Manual Agridoor[®]

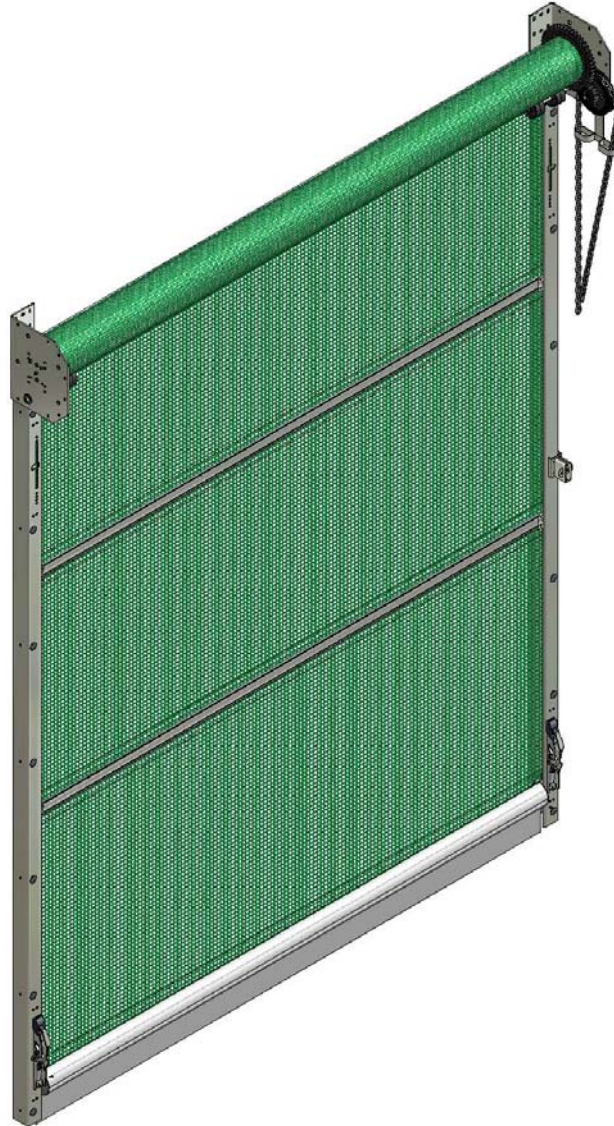

ENG

Installation Instructions



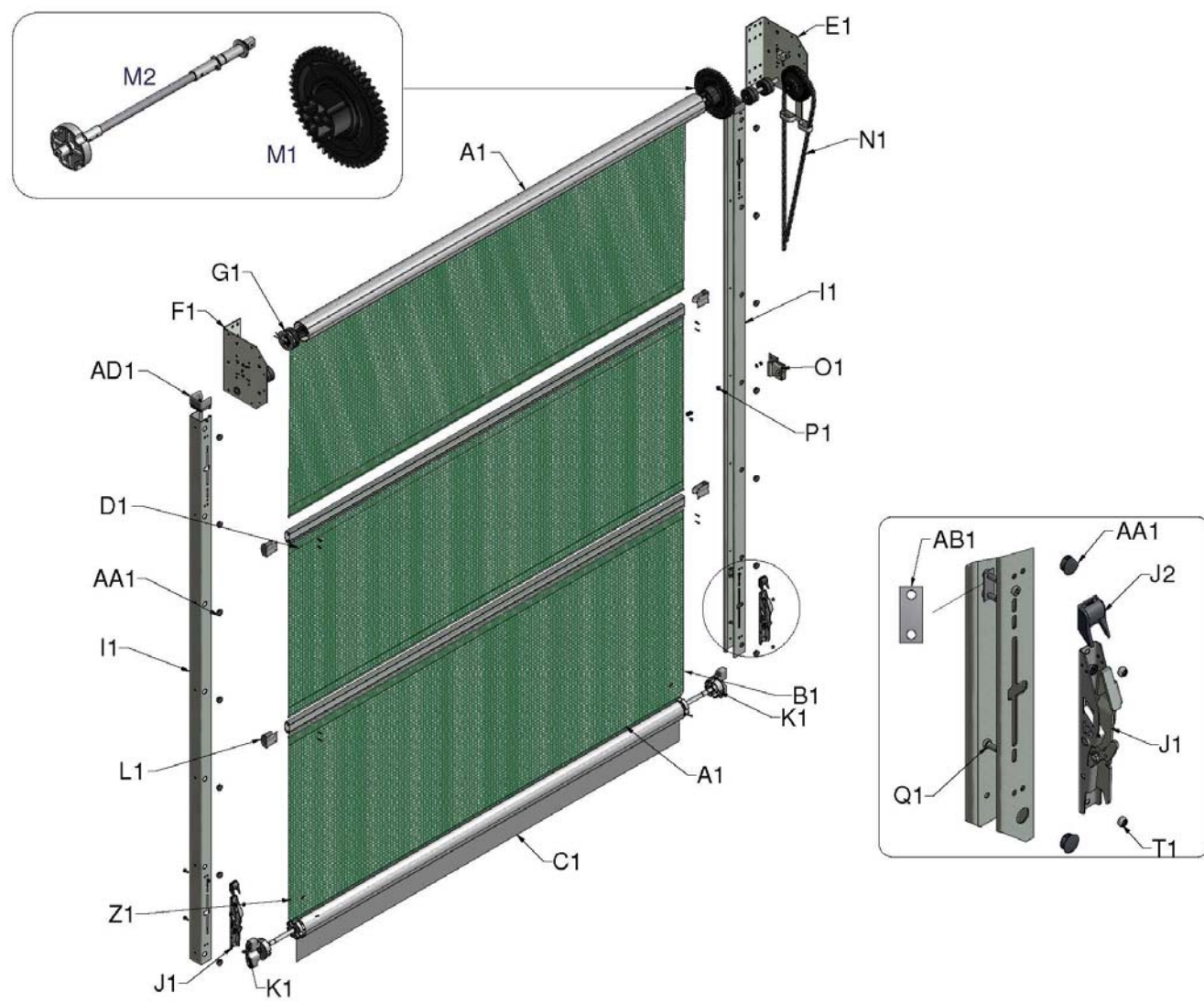

Figure 1, System Overview and Individual Components

INTRODUCTION**Parts List**

REFERENCE:	QTY	PRODUCT DESCRIPTION
A1	2	Top and Bottom Tubes
B1	*	Fabric Panels
C1	1	Lower Flap
D1	*	Wind Bars
E1	1	Drive Bracket
F1	1	Free End Bracket
G1	1	Spring Assembly (Left-Hand Insertion Shown)
H1	*	6mm Nylon Insert for Fabric (not shown)
I1	2	'C Section Guide Rail (4 supplied in some instances)
I2	4	Aligning Pins if Guide Rails Require Joining (not shown)
J1	2	Locking Catch
J2	2	Locking Catch Cap
K1	2	Bottom Tube Insert
L1	*	Windbar Protection Cap
M1	1	25cm Gear
M2	1	Gear Drive Shaft
N1	1	Operating Chain
O1	1	Chain Keep and Bracket Assembly
P1	2	M8 x 16 Flanged Bolts to Fix Chain Keep
Q1	4	M8 x 20 Hex Bolts to Fix Locking Catches
R1	*	M8 x 30 Hex Bolts for Fixing Guide Rails (not shown)
S1	8	M10 x 30 Hex Bolts for Fixing Top Brackets (not shown)
T1	12	M8 Nylocs
U1	*	M8 Nuts
V1	*	M8 Washers
V2	8	M10 Washers
W1	1	350 x 127mm Yellow Template (not shown)
X1	8	M10 Nylocs
Y1	2	M4 x 75mm Split Pins to Secure Top Tube to Brackets
Z1	*	M4 x 25 Self-Drilling Screws for Fixing Fabric Panels, Inserts and Flap.
AA1	26	Guide Rail Plug
AB1	2	Locking Catch Adjuster Stop
AC1	2	M6x12 Bolt and Nyloc Nut
AD1	1 pr	Guide Rail Guide

* Quantities according to size of door

Your Safety

The larger doors will require a mechanical lift to mount the roller assembly onto the top brackets. The respective weights are given in the table below based on standard material. Add 5% to this figure for doors supplied with 'HP' fabric, and 15% for doors supplied with black Stockscreen and solid fabrics.

WIDTH	HEIGHT			
	3.1m	4.1m	5.1m	6.1m
2.5m	38kg	43kg	49kg	55kg
3.0m	43kg	50kg	57kg	70kg
3.5m	48kg	56kg	71kg	79kg
4.0m	53kg	69kg	78kg	87kg
4.5m	65kg	75kg	86kg	102kg
5.0m	70kg	82kg	99kg	110kg
5.5m	76kg	88kg	106kg	119kg
6.0m	81kg	100kg	114kg	128kg

Table 1, Roller Assembly Weights

ENG

Pre-Installation Check

Figure 2 indicates space required to install your door, with additional information for mounting multiple doors in series.

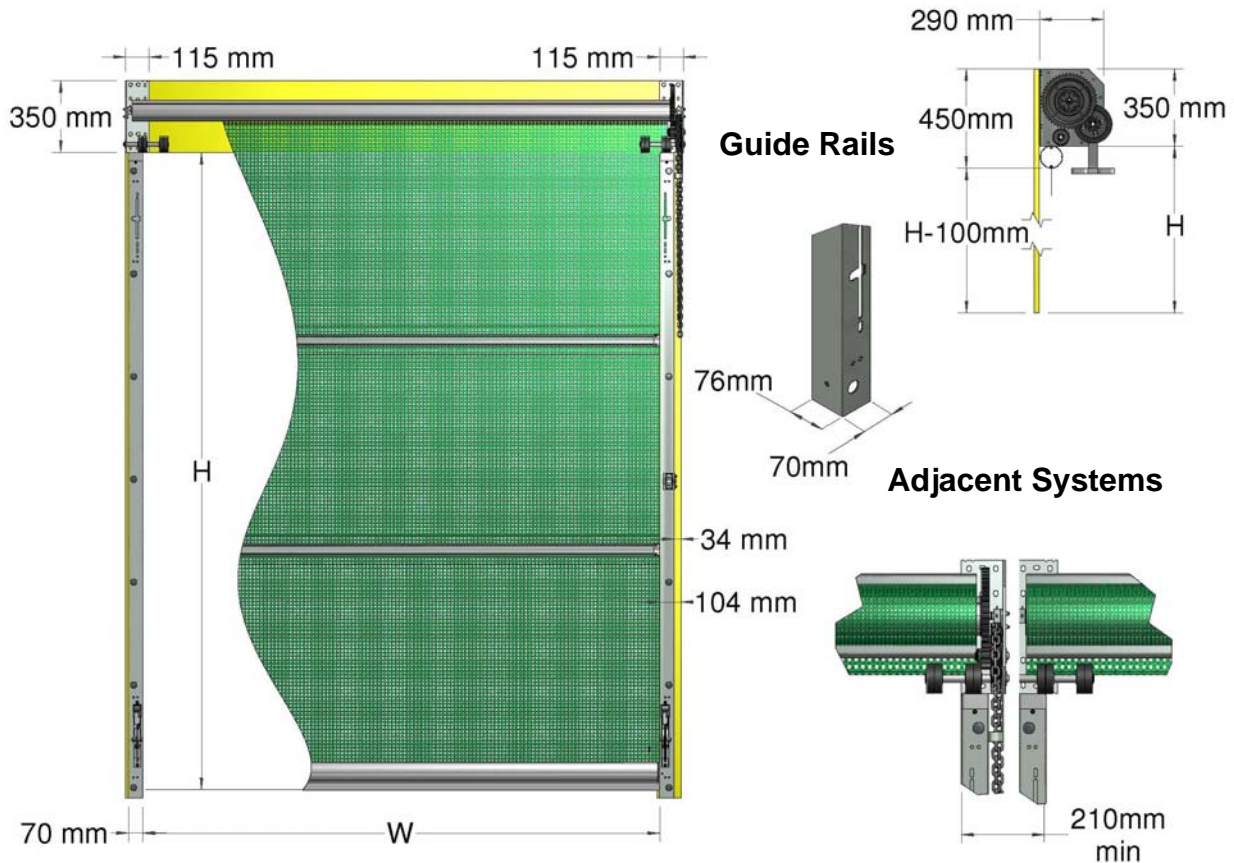

Order Width (m)	Fabric Width, W (m)
2.5	2.5
3.0	3.0
3.5	3.5
4.0	4.0
4.5	4.5
5.0	5.0
5.5	5.5
6.0	6.0

Order Height (m)	Max Height, H (m)
3.1	3.1
4.1	4.1
5.1	5.1
6.1	6.1

Figure 2, Fitting Requirements



CAUTION: To safeguard against any danger points, the minimum height 'H' of any door is 2.5m. In the event of door failure, the door must not form the only means of exit from the building to which it is fitted.

Wind Loadings

The structure to which the door is fitted needs to be of adequate strength to resist the following wind loads.

Wind Speed (km/hr)	Wind Load (N)*	Wind Load (Kg)*
70 km/hr	= W x H x 233	= W x H x 2285
100 km/hr	= W x H x 481	= W x H x 4718
140km/hr	= W x H x 933	= W x H x 9152

**No allowance made for safety margins*

ENG

Right or Left Hand Drive

Your door will be supplied in accordance with the drive orientation specified when ordered. The images and text in these Instructions are based on a door with a right-hand drive, if you have ordered a left-hand drive then reverse the references. To change the orientation of your product :

- Top Brackets: The mounting plate is non-handed with a pair of holes for left or right orientation, which are marked 'L' and 'R'. To change orientation remove the item from the plate and secure on the opposite hand.
- Spring: See Appendix I for details of spring conversion.
-

Installer Competence

The installer should be able to demonstrate the required level of competence via evidence of installing similar products or formal training. If competence cannot be proven then they should not be allowed to install the product.

Product Description

The Agridoor® is a manually operated vertically moving rolling door comprising of a series of linked flexible curtains capable of being rolled and for which the main intended uses are giving safe access for goods and vehicles accompanied or driven by persons.

Items required by the Installer

Standard tool kit including:

- Electric drill
- Angle grinder
- Sharp pair of scissors or knife
- Spirit level
- Bolts for fixing the brackets to steel up to 12mm thick are supplied, if fixing to a wooden or concrete building you will require eight M10 fixings to fasten top brackets and M8 fixing for guide rails at 1m centres.

ENG

Key Instructions

CAUTION: Potentially hazardous situation: must be avoided otherwise injuries may result.



ATTENTION: Observe the given instructions otherwise the product or adjacent items may be damaged

NOTE: Helpful comments and information to assist in installation or use of your product

NOTE: Before starting the installation it is advisable to read these instructions completely to understand the procedure. Keep the instructions supplied for reference purposes.

NOTE: Colour versions of the installation instructions can be downloaded from our website:

www.galebreaker.com

INSTALLATION

1. Check the contents of your door against the parts list using Figure 1. Do not let the screen material come into contact with any sharp objects or edges.

Fitting the Top Brackets

ENG

2. Using the template as a drilling guide, fit the free end bracket (F1) and drive end bracket (E1) at the required height with M10 fixings (S1). Do not use the bottom set of holes, the fixings may interfere with the rolling action of your door. These brackets have been pre-assembled to match the position of the operating chain when your door was ordered. The door has been designed such that the tops of the guide rails are fitted directly underneath the brackets (Figure 3), aligning with the letter 'F' for the free-end bracket and the bracket edge for the drive end. When fitting the brackets it is essential that they are level and upright.

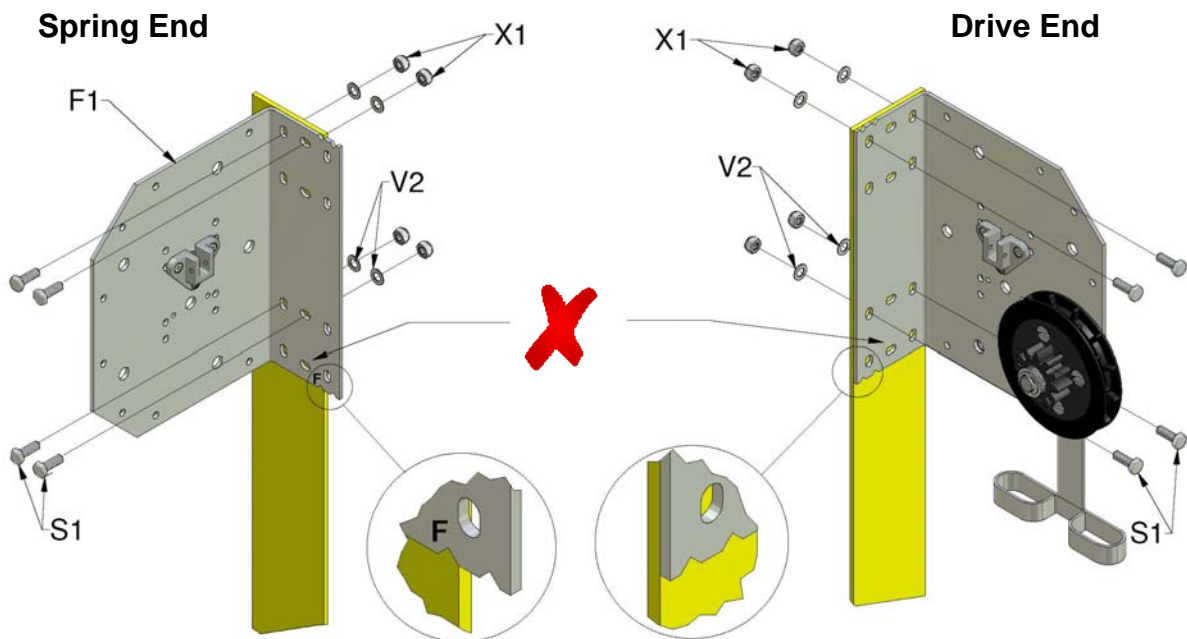



Figure 3, Top Bracket Positioning

 <p>CAUTION</p>	<p>CAUTION: Referring to Table 1 on page 4, ensure the building is of sound construction and that the most suitable type of fastener is used. Use only M10 bolts or greater to fit these items and ensure they are securely fastened to the building. Failure of these fixings will result in your door falling off the building, potentially injuring operators and bystanders.</p>
---	---

Cutting the Top tube, Windbars, and Fabric

3a. If it is required to cut your door, measure the daylight gap between the inside face of the top brackets (A) and cut to the following rules (Figure 4a), do not cut the lower flap and bottom tube at this point.

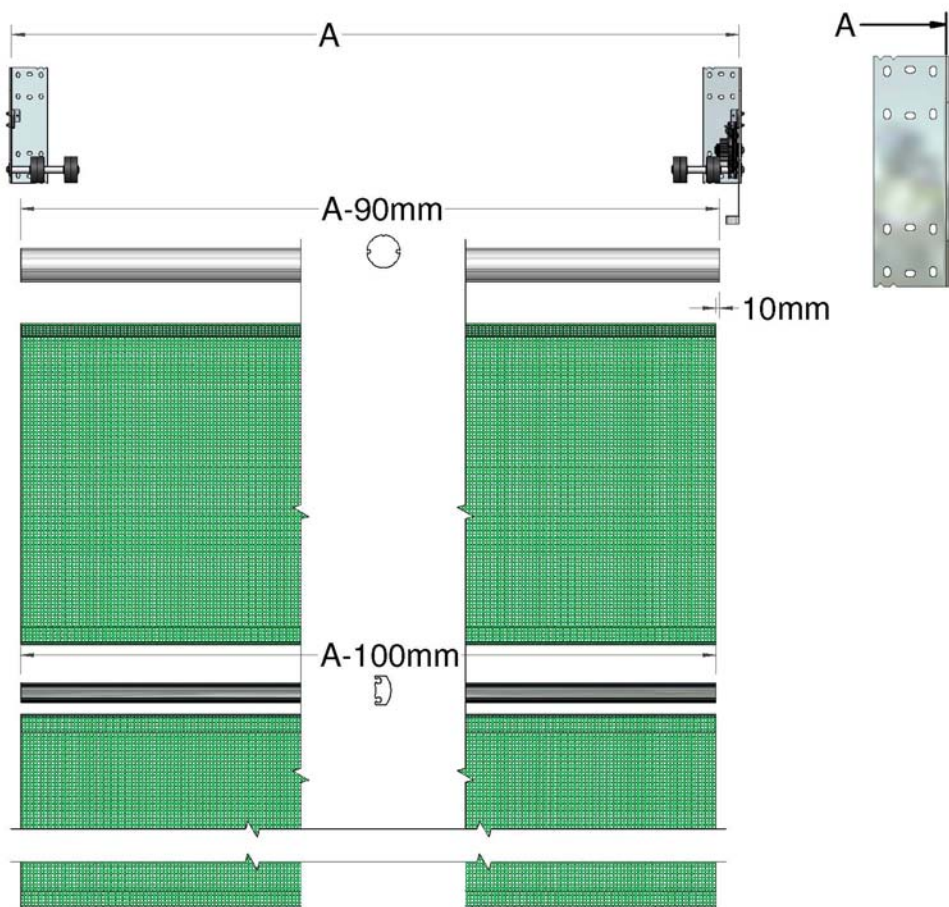
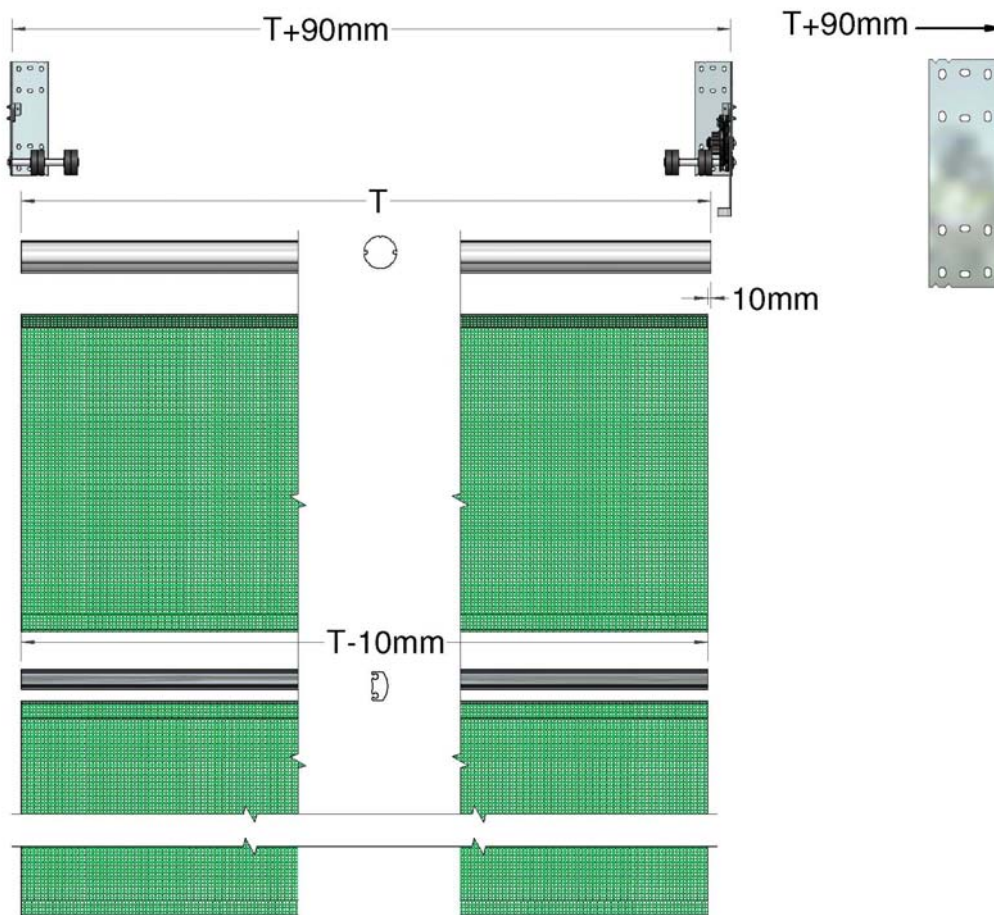

Figure 4a, Standard Cutting Lengths of Tubes and Fabric

Top Tube	=	Distance between inside faces -90mm (-0.090m)
Fabric Panels	=	Distance between inside faces -100mm (-0.100m)
Windbars	=	Distance between inside faces -100mm (-0.100m)

ENG

- 3b. If your door can be mounted without cutting the top tube, follow the dimensions shown in Figure 4b, note the windbars, fabric, bottom tube and flap will always have to be cut.



ENG

Figure 4b, Top Bracket Spacing When Not Cutting Tube, Windbars and Fabric

4. Slide the nylon insert (found inside the windbars) into the pocket of the fabric and cut to suit, slide the fabric panels and windbars onto the top tube assembly (Figure 5a).

NOTE: To ease the insertion of the fabric panels into the windbars ensure all metal burrs are removed, and use a lubricant such as light oil or washing-up liquid.

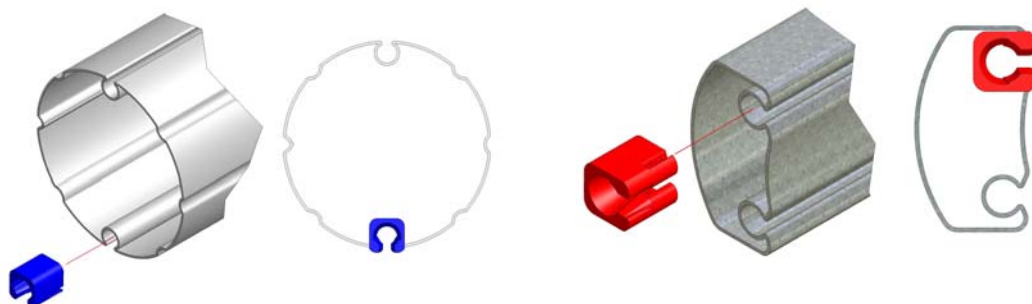

ENG

Push the Flute Guide Insert over the end of the flute in the tube or windbar to protect the fabric sheet as it is being fitted. When the fabric is inserted remove the Flute Guide Insert from the end of the flute.

Ensure that the panels go in the correct position, as they are different heights, refer to Figure 5b.

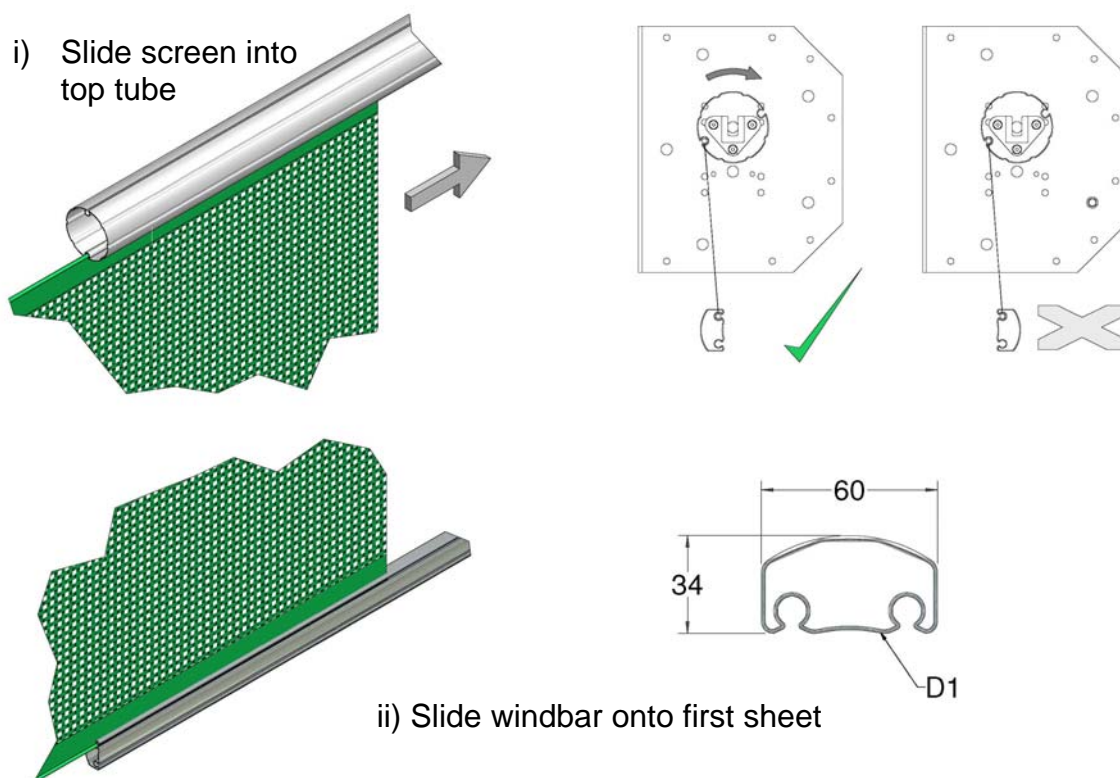
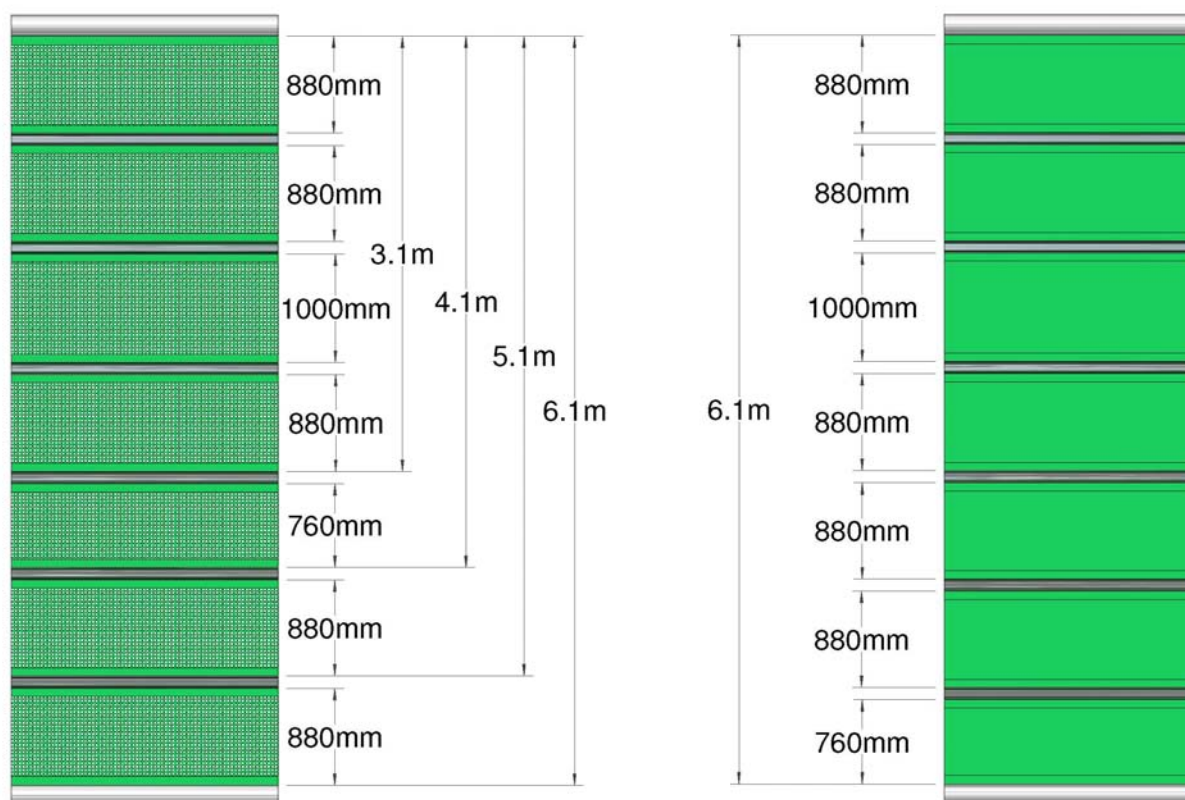

Figure 5a, Sliding Fabric Panels and Windbars onto Top Tube

6.1m Solid Material (only)



ENG

Figure 5b, Fabric Panel Layout

Secure the screen in each corner using the 25mm self-drilling screws supplied (Z1), ensuring the windbar protection caps (L1) are fixed at the same time. To prevent damage to the caps do not over tighten the screws. It is important to tension sheet sideways before fixing to remove creases (Figure 5c). Do not secure the fabric to the top tube at this point.

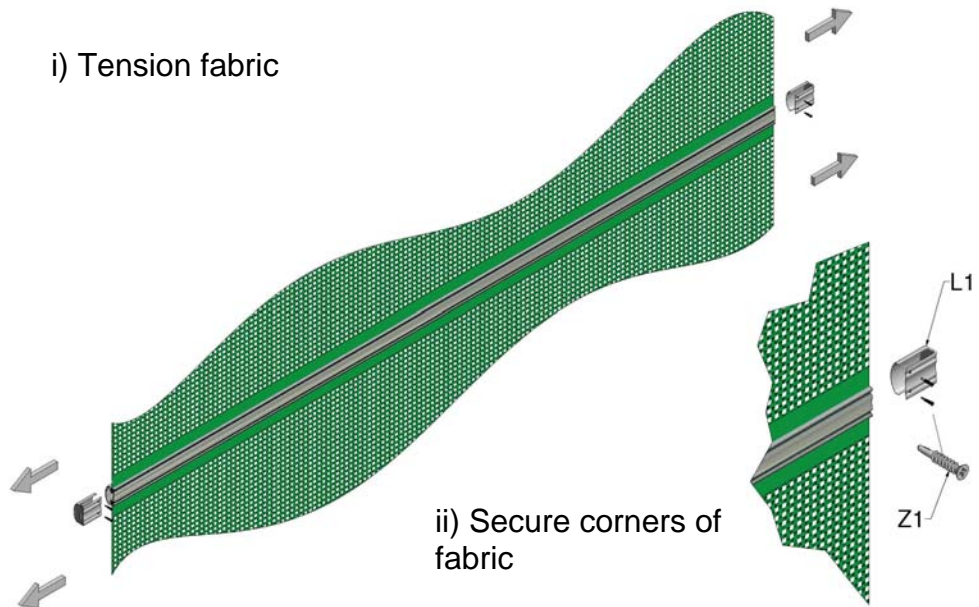

Figure 5c, Securing Fabric

5. Roll the windbars and fabric panels onto the top tube. It is important that when the door is hung the fabric should come off the back of the top tube, between the tube and the building face (Figure 6a).

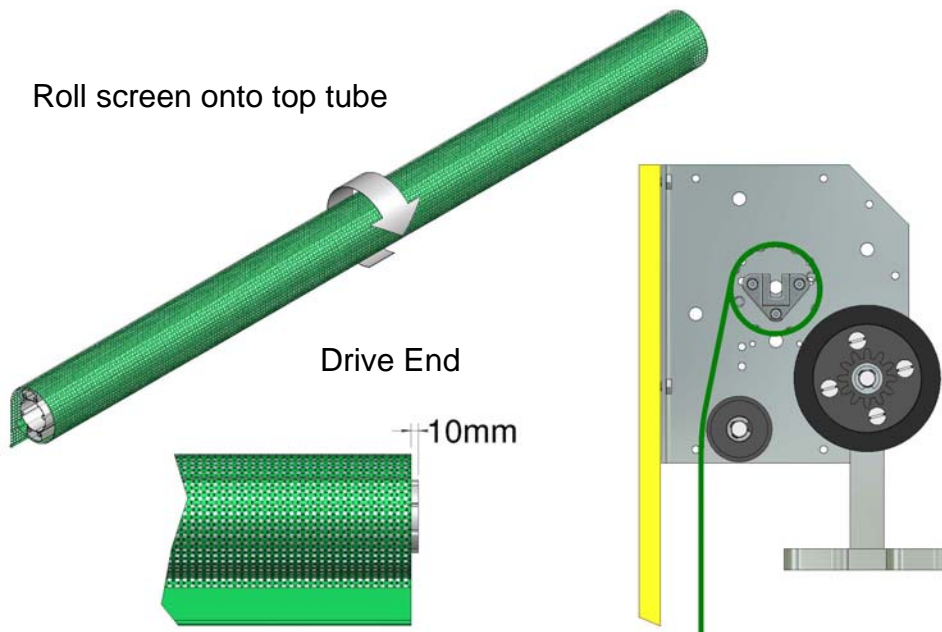
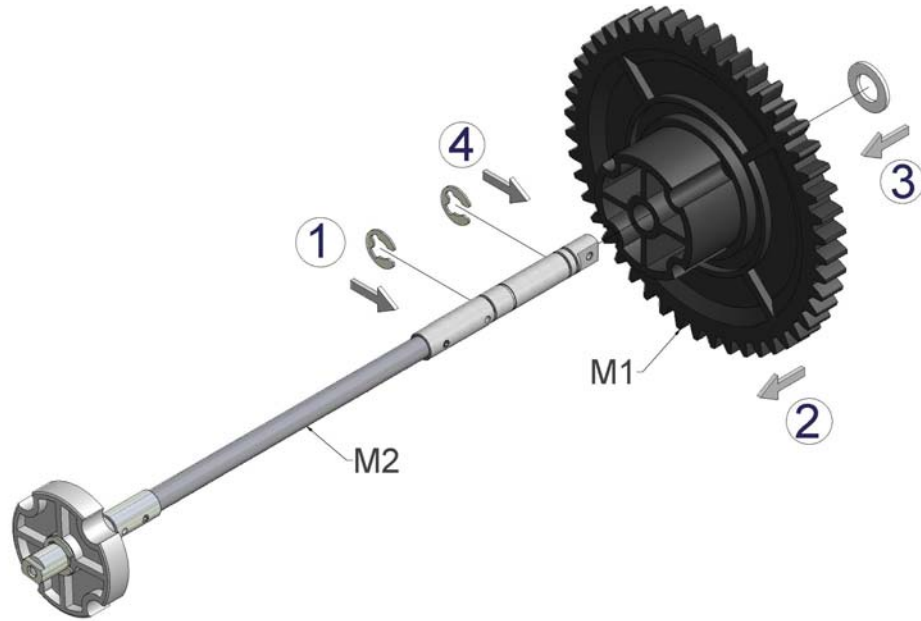

Figure 6a, Fabric Attached to Top Tube and Rolled Up

Assemble the drive shaft by sliding the 25cm gear (M1) on to the drive shaft (M2). The 25cm gear is located using the circlips and washer supplied, Figure 6b.



ENG

Figure 6b, Assembly of Gear Drive Shaft

Slide the spring assembly (G1) into the top tube to match the orientation of the free end bracket, insert drive shaft (M1) into opposite end. Refer to Figure 6c for right hand drive and Figure 6d for left hand drive.

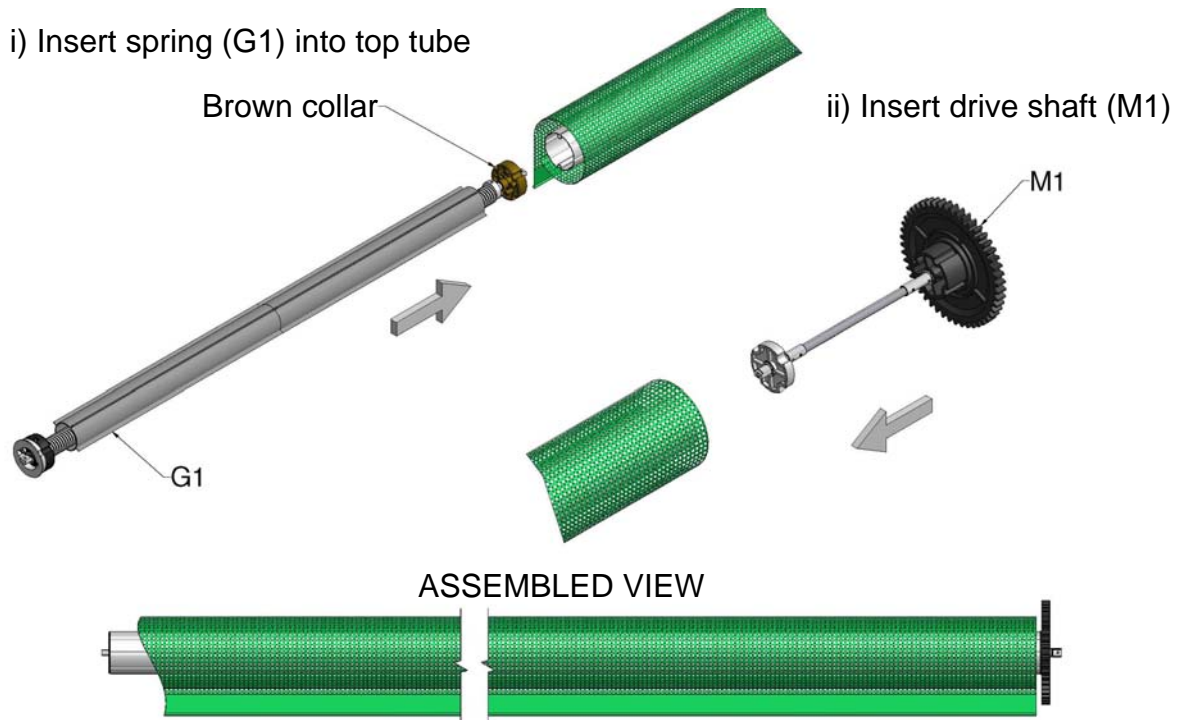

Figure 6c, Top Tube Assembly (Right Hand Drive)

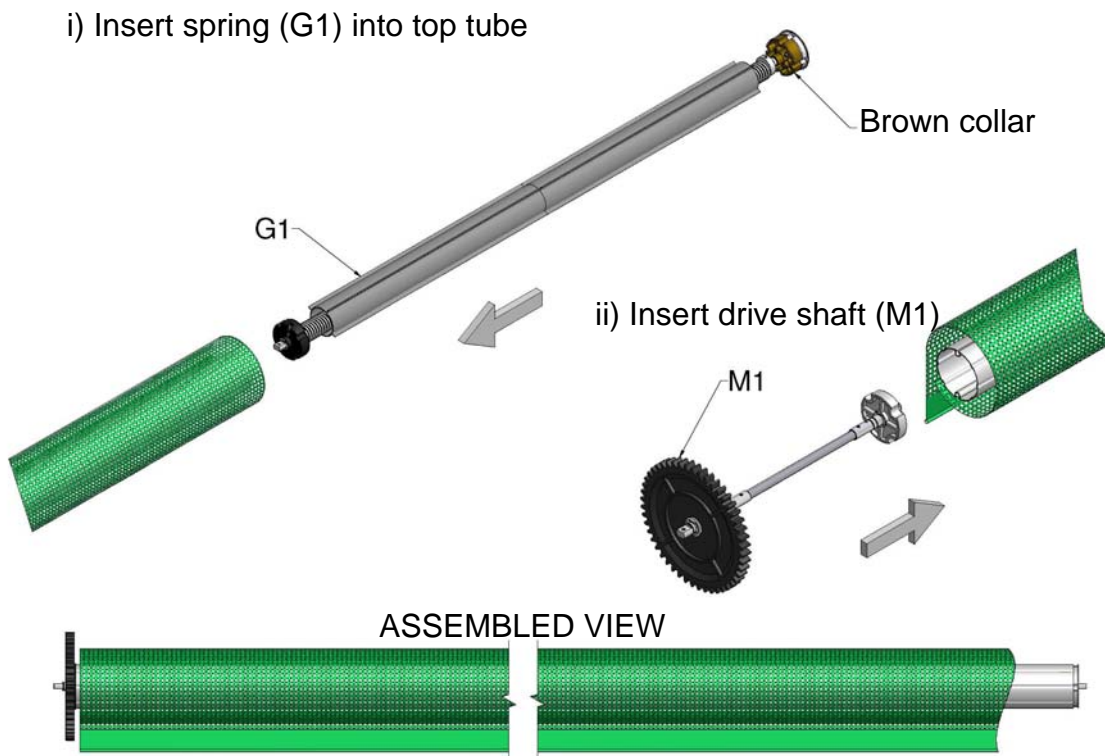

Figure 6d, Top Tube Assembly (Left Hand Drive)

ATTENTION: It is vital that the spring assembly is fitted correctly, as shown in Figure 6c or 6d, otherwise the spring will suffer terminal damage, for which Galebreaker is not liable, i.e. if you have a right hand operated door as shown in Figure 6c the Brown collar should be inserted first.

NOTE: If you wish to fit the spring to the opposite side to that ordered, refer to instructions in Appendix I.

Hanging the door

- When lifting the roller assembly onto the top brackets, ensure that the shafts slide completely into the base of the cup brackets (Figure 7). Lock the shafts in place with the M4 x 75 split pins supplied (Y1).

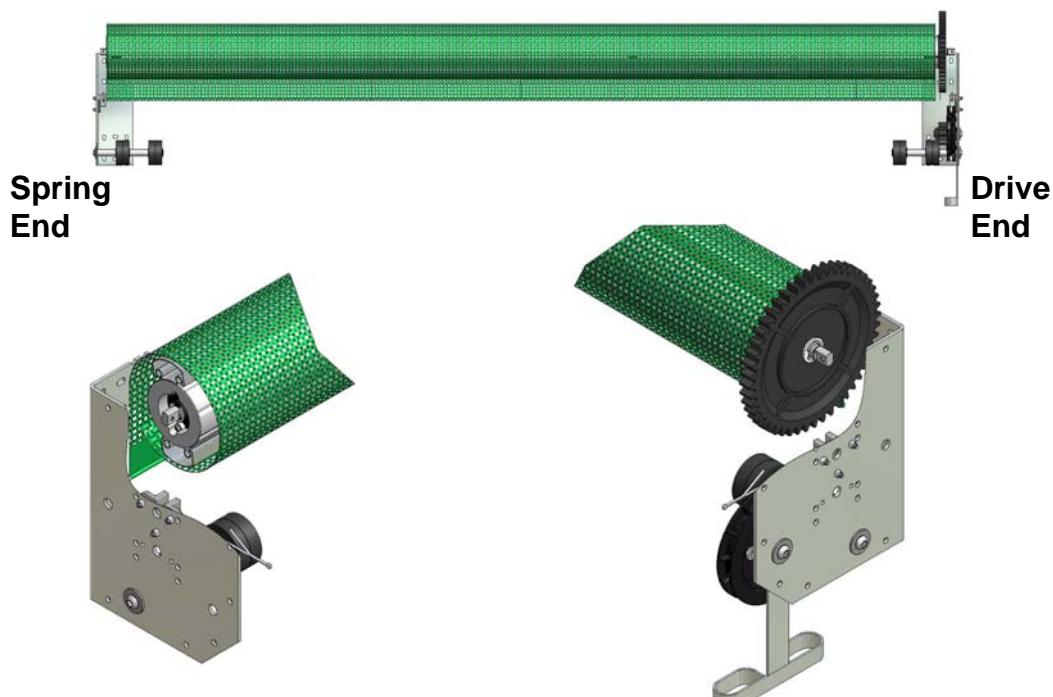

Figure 7, Locating Top Tube In Brackets (RH Drive Shown)

CAUTION: It is important to insert the split pins, this will prevent your door falling if the end brackets are struck, thereby potentially injuring operators and bystanders.

7. Feed the operating chain (N1) around the chain wheel, through the chain guide and trim to length if required (Figure 8). Make chain into a continuous loop by sawing through one link, bending open, and joining the two ends. After closing, file away any sharp edges to ensure the chain does not injure operators; it is unnecessary to weld the link shut.

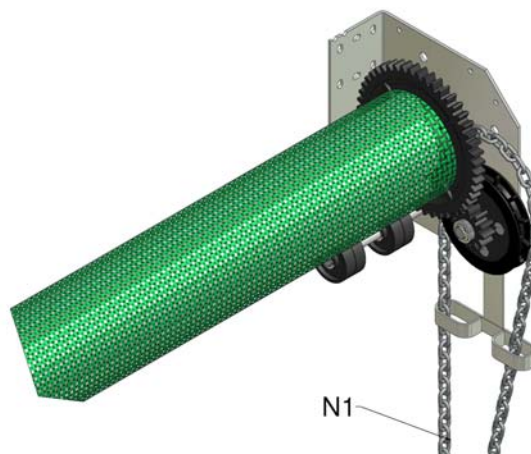

Figure 8, Installing Operating Chain

Fixing the Guide Rails

8. Lower your door fully, when the fabric and windbars are down you will be able to check the top tube is level and position the guide rails. Raise your door, the fabric and windbars will now stack tightly around the top tube, which will make tensioning the spring easier in point 13 below. Tie up the roller assembly (Figure 9).

ENG



Figure 9, Tie Up Roller Assembly

9. Equally cut the two guide rails (I1) to fill the gap between the underside of the top brackets and the ground allowing 4 cm for the guide (AD1). Make sure that the un-cut end with the slot and holes is at the bottom ready to accept locking catches. Fit the pair of guides into the top of the guide rails (cut end) and secure with the M6x12 bolt and nut (AC1) in the front face, Figure 10.

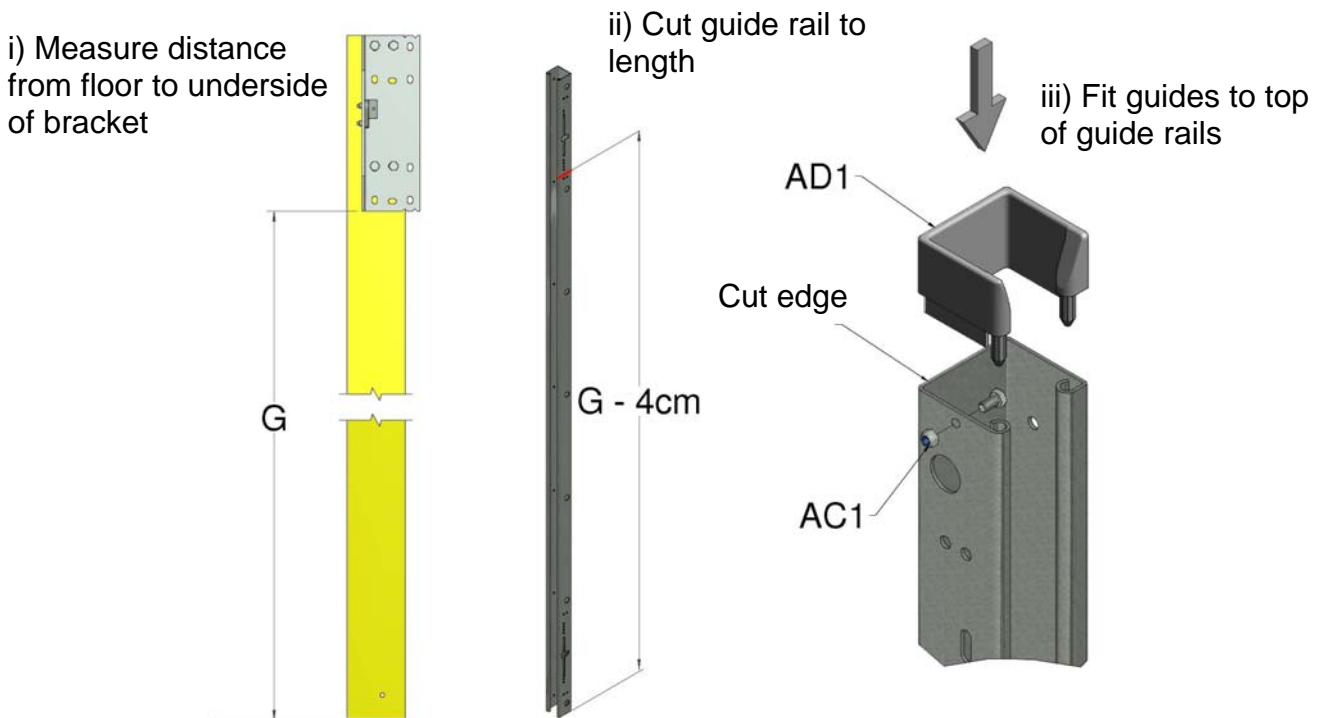



Figure 10, Cutting Lengths of Guide Rails



CAUTION: Use only M8 bolts or greater to fit these items and ensure they are securely fastened to the building.

10. Fit the guide rails to the building as shown in Figure 11 with M8 fixings using the pre-punched holes at 100cm centres. If the rails are supplied in part lengths, align each section with the joining pins (I2) supplied (Figure 11).

ENG

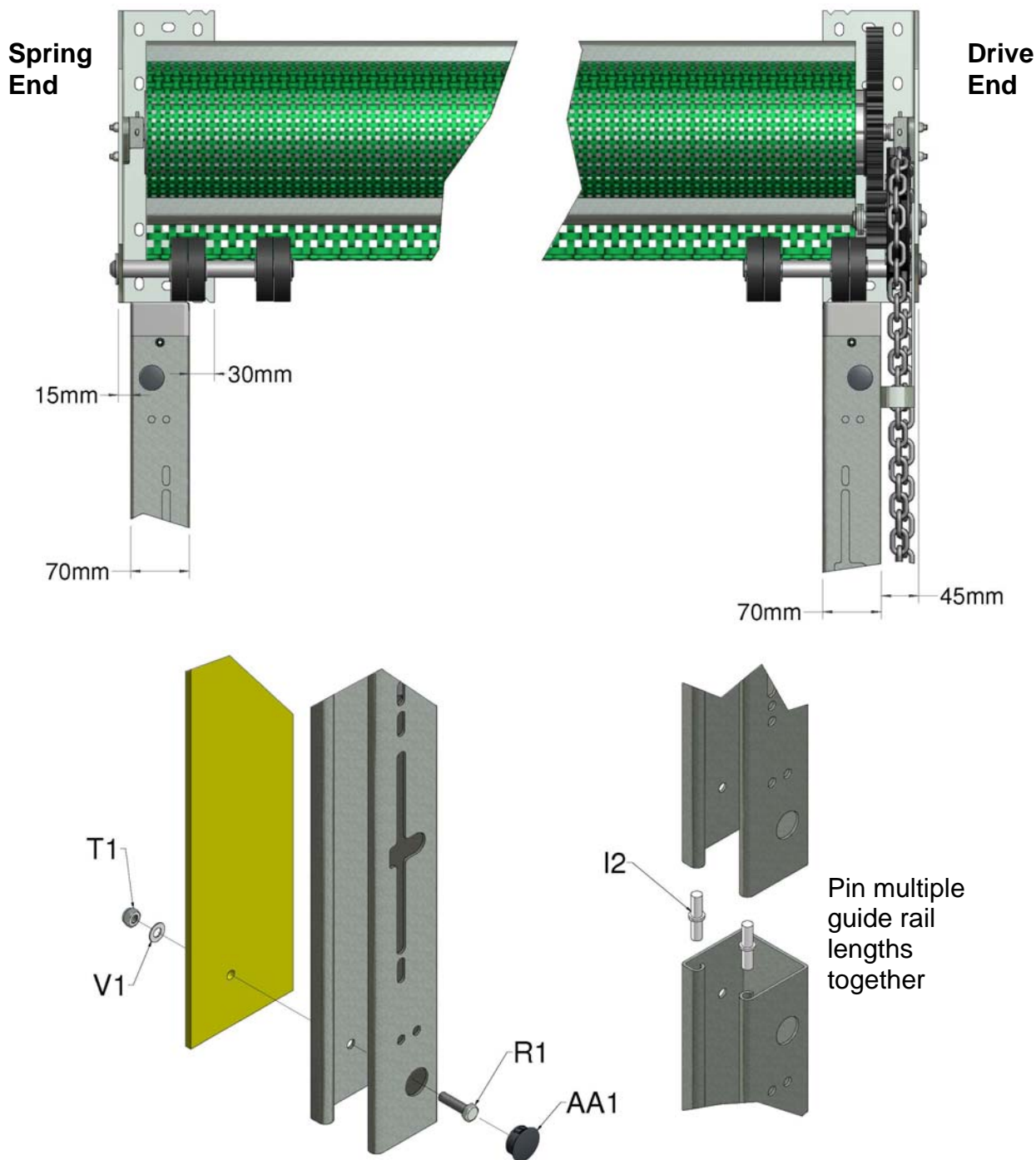

Figure 11, Bolting of Guide Rail and Joining of Guide Rail to Wall

11. Bolt the locking catches (J1) to the pre-punched slots at the base of the guide rails using the M8x20 set screws (Q1) and lock nuts supplied (T1). Pass the upper catch screws through the locking catch stop plate (AB1) fitted on the inside of the guide rail to prevent the catch sliding up the pre-punched slots. Ensure the swinging arm of the locking catch clears the long slot in the guide rail (Figure 12). Fit caps (J2) to top of locking catches.

ENG

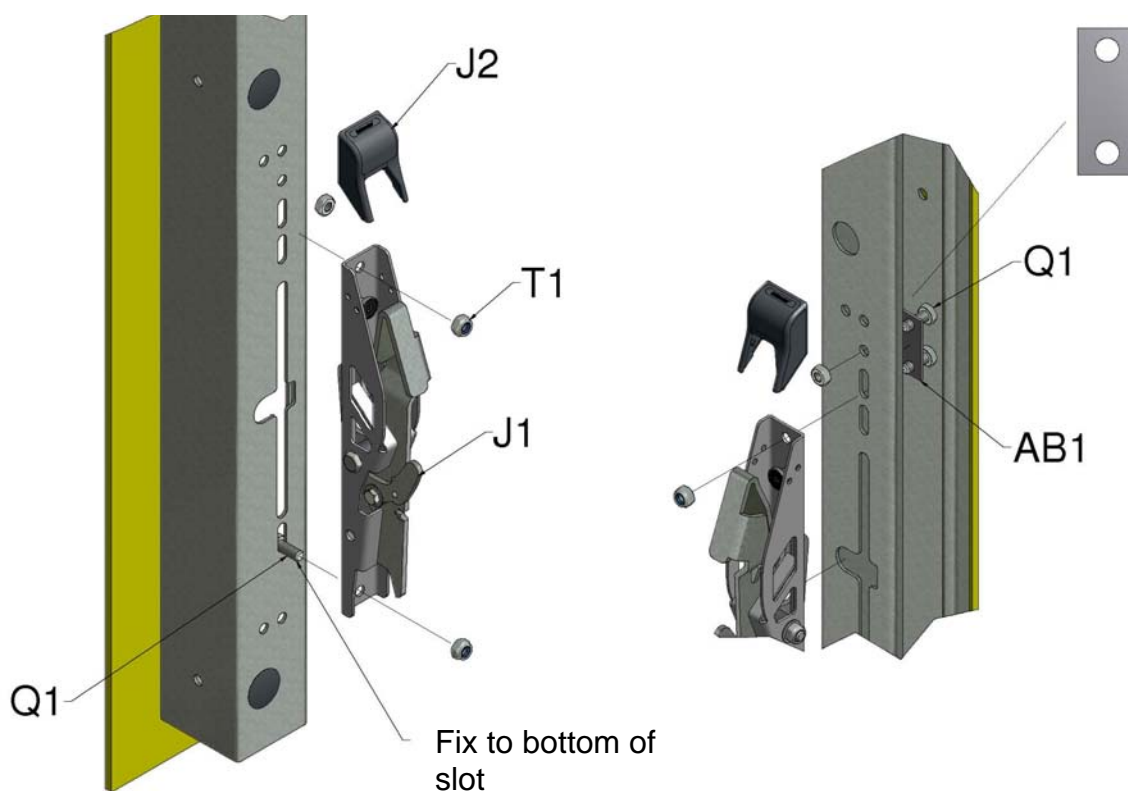

Figure 12, Bolting of Locking Catches

12. Install the chain keep and mounting bracket (O1) to the guide rail by drilling 2 No 8.5mm holes and using the M8x16 flanged bolts (P1). The height of the chain keep depends upon your installation (Figure 13), but is typically 1.5m high.

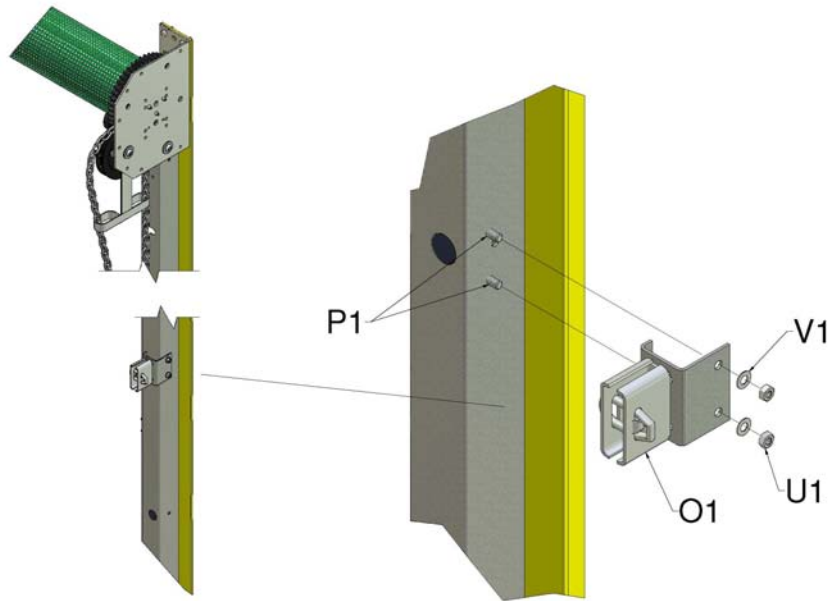

Figure 13, Attaching Chain Keep to Guide Rail

Tensioning the Spring Mechanism

13. Pre-tension the spring mechanism by rotating the roller assembly in the direction shown in Figure 14, this is done by pulling down on the outer chain. The number of pre-tension turns is given in the table below. When the required number of turns has been reached, lock the operating chain into the chain keep (O1).

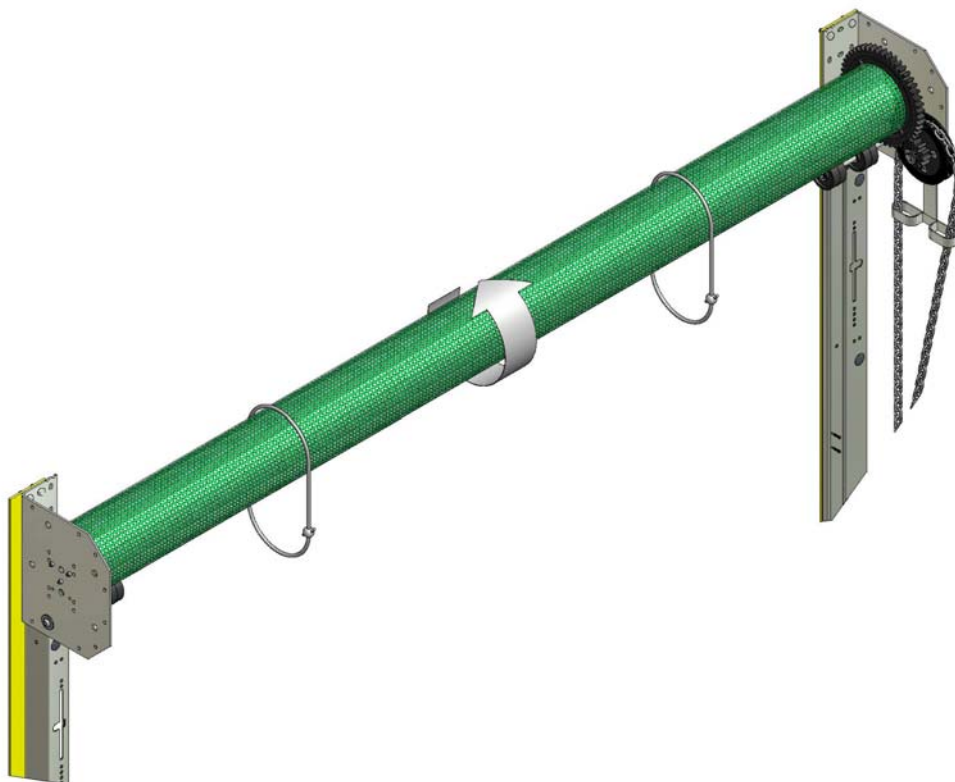

Figure 14, Tensioning of Spring

WIDTH	HEIGHT & No. OF TURNS			
	3.1m	4.1m	5.1m	6.1m
2.5m	6 (<i>1.4m long</i>)	7	9	8
3.0m	9 (<i>Spring</i>)	10	9	8
3.5m	11	10	8	8
4.0m	11	8	9 (<i>2.1m long</i>)	8
4.5m	8	9	9 (<i>Spring</i>)	7
5.0m	9	9	7	7 (<i>3.0m long</i>)
5.5m	10	9	8	7 (<i>Spring</i>)
6.0m	10	8	8	7

ENG



ATTENTION: To prevent spring damage, do not over-tension.

Installing the Lower Tube

14. Cutting bottom tube and flap (Figure 15):

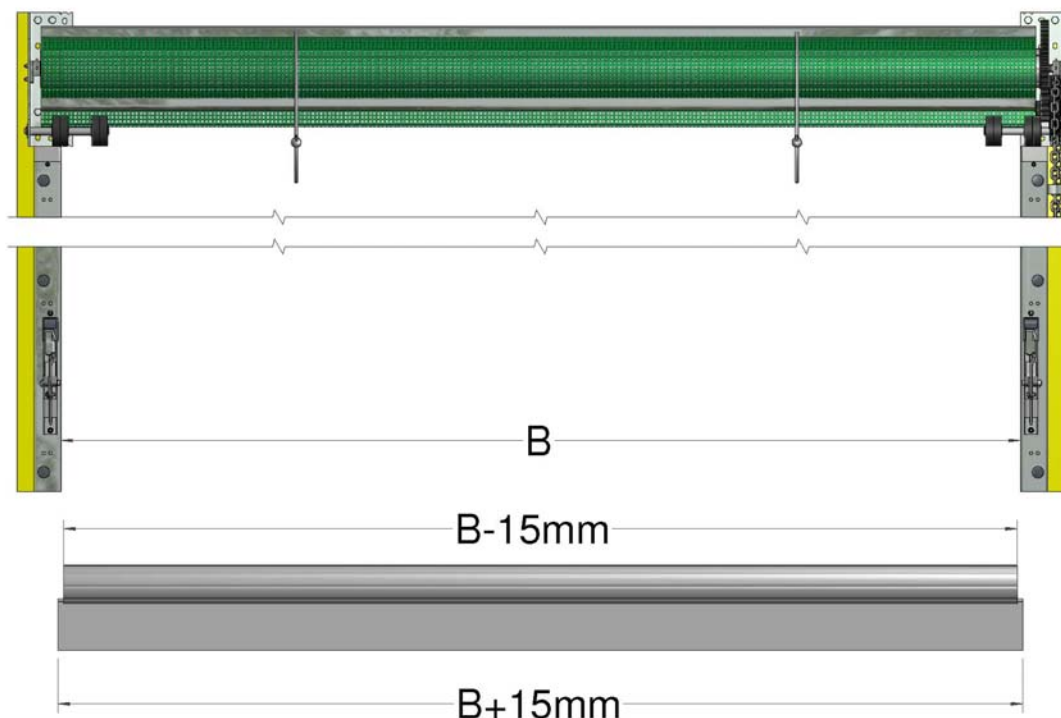

ENG

Figure 15, Cutting Length of Bottom Tube, Insert and Bottom Flap

Bottom Tube	=	Gap between inside face of Guide Rails -15mm (-0.015m)
Insert	=	Gap between inside face of Guide Rails +15mm (+0.015m)
Bottom Flap	=	Gap between inside face of Guide Rails +15mm (+0.015m)

15. Slide nylon insert into the pocket of the flap (C1) and slide flap onto the bottom flute. Untie the top tube assembly and lower the door. Pull the bottom fabric panel outside the guide rails and slide on the bottom tube (Figure 16), centralise and trim excess fabric in each corner as shown in Figure 16. Push the inserts (K1) into the tube, and fix using the M4 x 25mm self-drilling screws (Z1) supplied, secure flap with same self-drilling screws.

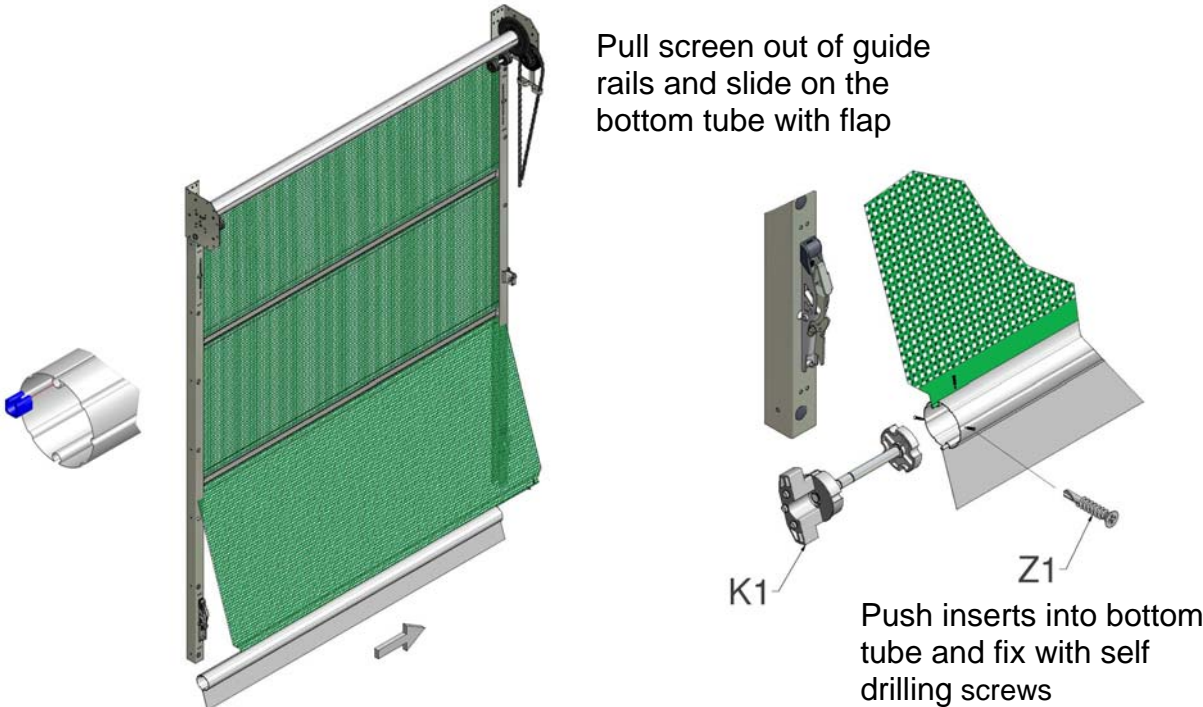

Figure 16a, Attaching Bottom Tube

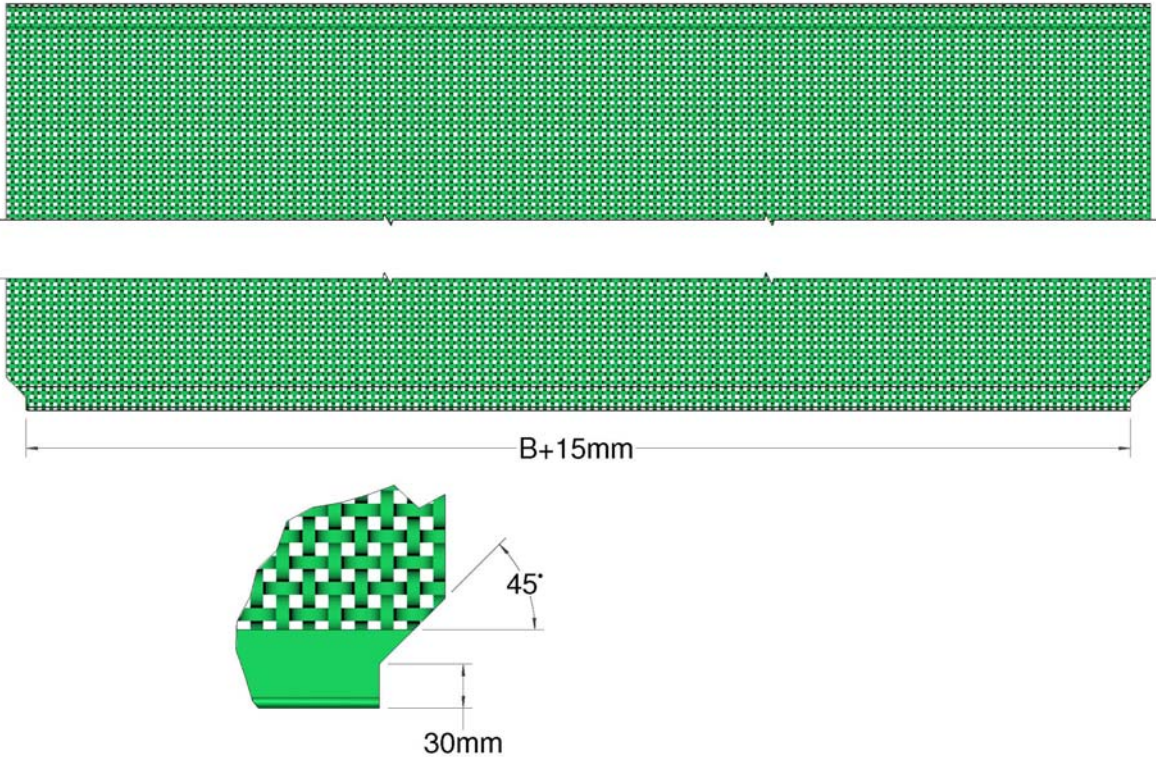

Figure 16b, Trimming Sheet

16. Lower your door fully and secure the fabric panel to the top and bottom tube with the self-drilling screws. It is important to tension sheet sideways before fixing to remove creases (Figure 17). Insert the screws into the top tube by a maximum of 35mm in from the edge to prevent damage to the spring. Insert one end of the bottom tube into the guide rail, lift and insert the other end into the opposite guide rail. Check the operation of the locking catches; it may be necessary to trim a small amount of fabric above the tube to allow the swinging arm to fully close.

ENG

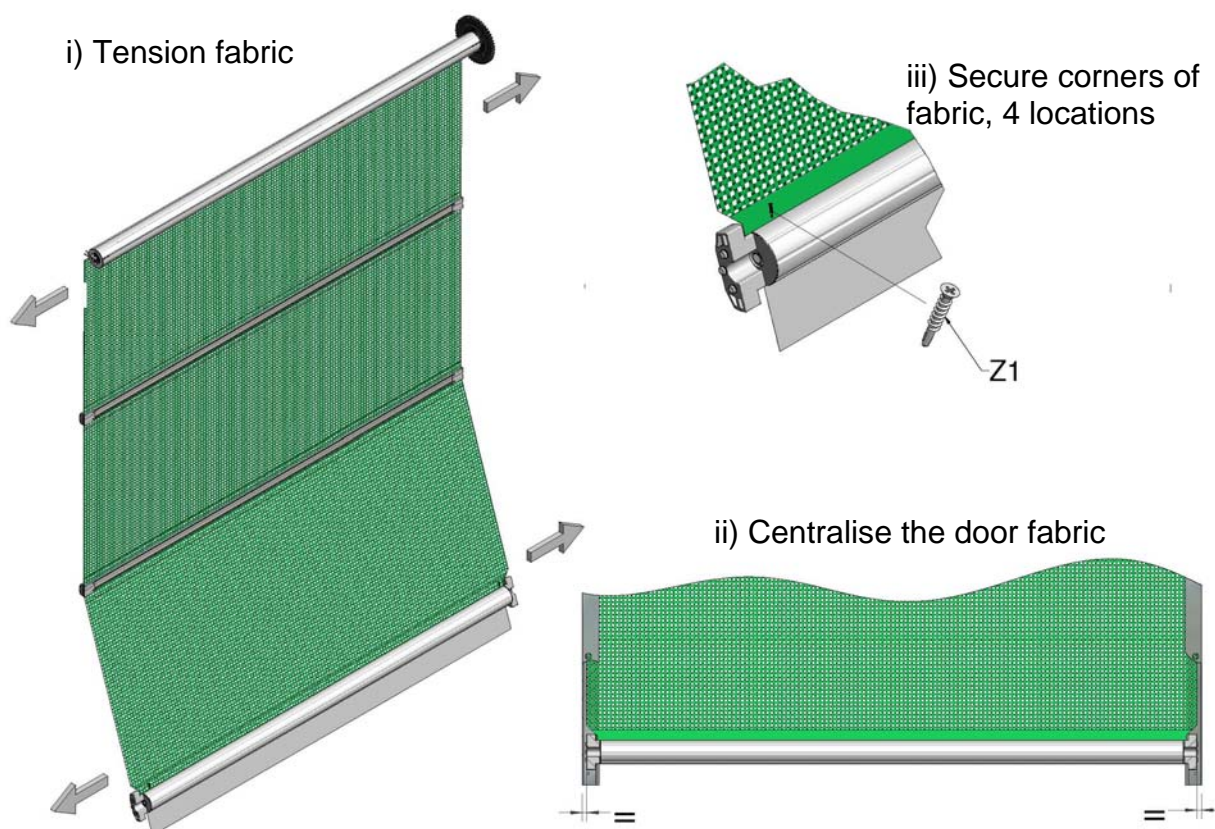

Figure 17, Centralising Screen

- Attach the locking catch instruction labels to the front of the guide rails at a convenient height, typically just above the chain keep. Attach the company detail label centrally to the front of the bottom tube.

ENG

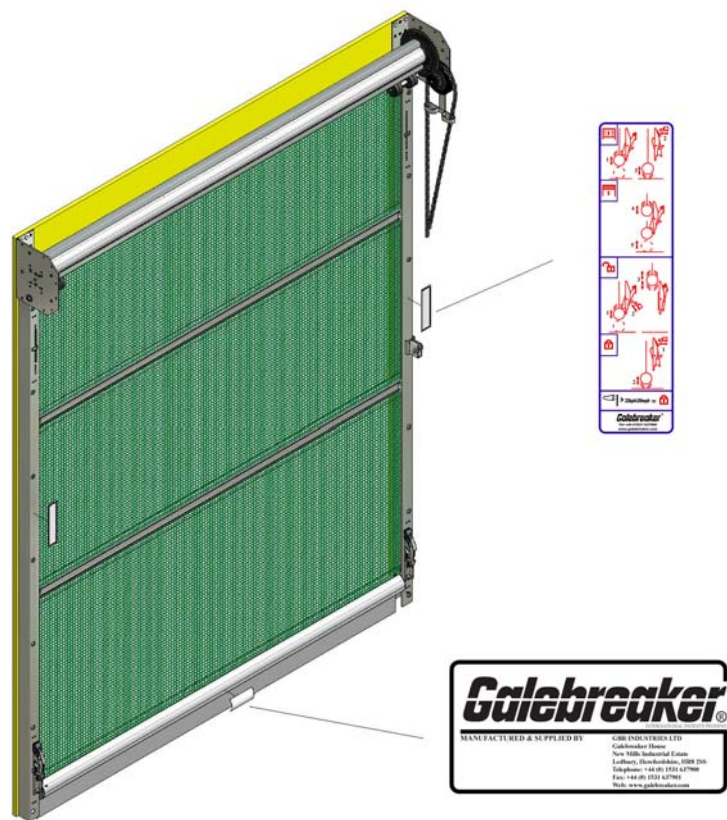
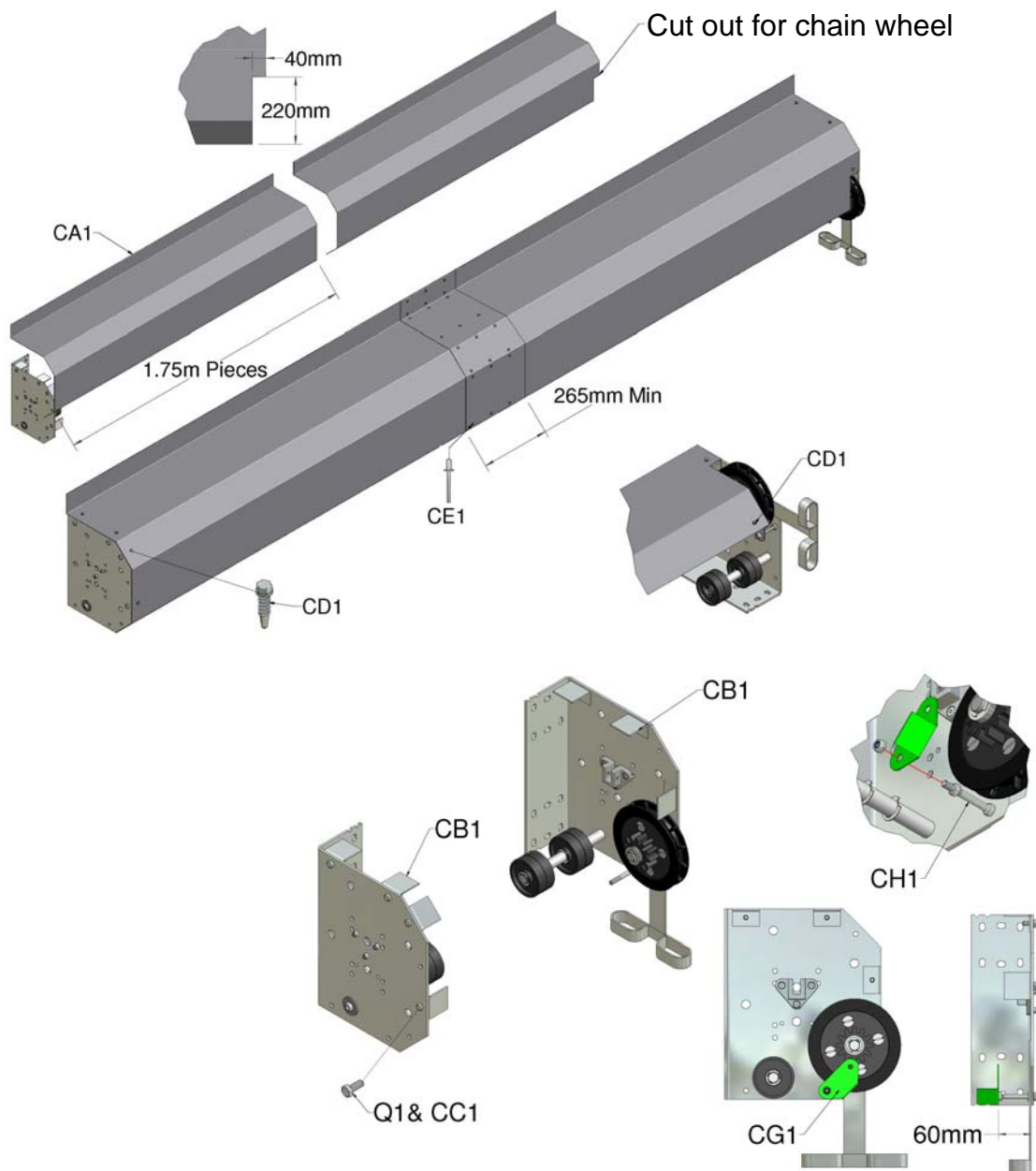

Figure 18, Attaching Labels

Installing Door Cowling (Optional)

18. Door Cowling (Optional at extra cost)



ENG

REF:	QTY	PART DESCRIPTION
CA1	*	1.75M Lengths of Cowling
CB1	8	Cowling Brackets
CC1	8	M8 x 20 Hex Bolts & Nuts
CD1	8	M5.5 x 19 Self Drilling Screws
CE1	*	M4.8 x 8 St Steel Rivets / per join
CF1	1	5mm Drill for rivets (not shown)
CG1	1	Cowling Bracket – Chainwheel
CH1	1	M8 x 70 Hex screw and nuts

Figure 19, Door Cowling Assembly

-
- C1. Fit cowling brackets, noting only three are on the drive bracket. Cut 40mm wide x 220mm high notch in one end of cowling to accept the chain-wheel.
- C2. Join cowling with a minimum overlap of 265mm (Figure 19). Secure with 30no. rivets, 6 in each of the five faces. Offer cowling to brackets and secure with M5.5 x 19 self-drilling screws supplied. Fix rear upstand to building, sealing to prevent water ingress if necessary.

NOTE: The Cowling is self-supporting and does not require intermediate brackets.

19. CE Marking Products under Construction Products Directive

It is the responsibility of the installer to check that the installation conforms to the specific safety features detailed in the Manufacturer's Installation Instructions, to issue the CE Declaration of Conformity and mark a product under the Construction Products Directive 89/106/EEC. To do this you will require the following which should be delivered with the product:

ENG

- 1) This set of Installation Instructions (*operating and maintenance instructions*)
- 2) Maintenance Log Book, (*including Installation Checklist and Customer Declaration of Conformity*)
- 3) 1 x Declaration of Conformity (Installer Copy) – *to be completed*
- 4) A CE Label

When CE marking a Galebreaker product, it is vital to follow the steps outlined below:

- a) Install the product as per instructions, with no adaptations or modifications and complete of the *Health and Safety Checklist* in the Maintenance Log Book.
- b) Complete the two 'Declarations of Conformity' using the following:
 - **Model Type:** As shown on CE Label
 - **Serial Number:** As shown on CE Label
 - **Installation Company:** Your company name
 - **Date Installed:** Date Installed
 - **Declaration made by:** Responsible Person
 - **Declaration and Instructions received by:** Customer's Signature
- c) Fix the supplied CE label to the bottom tube. The label should be accessible / visible. Where the serial number does not incorporate the door size, add the Product width and Product height to the end of serial number using a permanent marker pen. i.e. the full serial number should read

Serial Number: 1234 / AD W X H

[W] Product Width (m)

[H] Product Height (m)

- d) Your customer must be given a copy of the completed 'Maintenance Log Book' along with the 'Installation Instructions' supplied by Galebreaker. These should be stored adjacent to the door controls for reference purposes.
- e) Finally, ask your customer to sign the 'Declaration of Conformity' (Installer Copy). This important document must be filed back at the office of the installer for future reference

ENG



Figure 20, CE Label Location

YOUR DOOR IS READY FOR USE

OPERATION AND MAINTENANCE

How to use your door

- Windspeed less than 32kph / 20mph

In light wind conditions, the locking catch can be disabled. If the locking catch (J1) is active, disable it by pushing on the disengagement lever (Figure 20). Pull the operating chain to open and close your door, insert both chains into the chain keep to hold the door at any level.

ENG

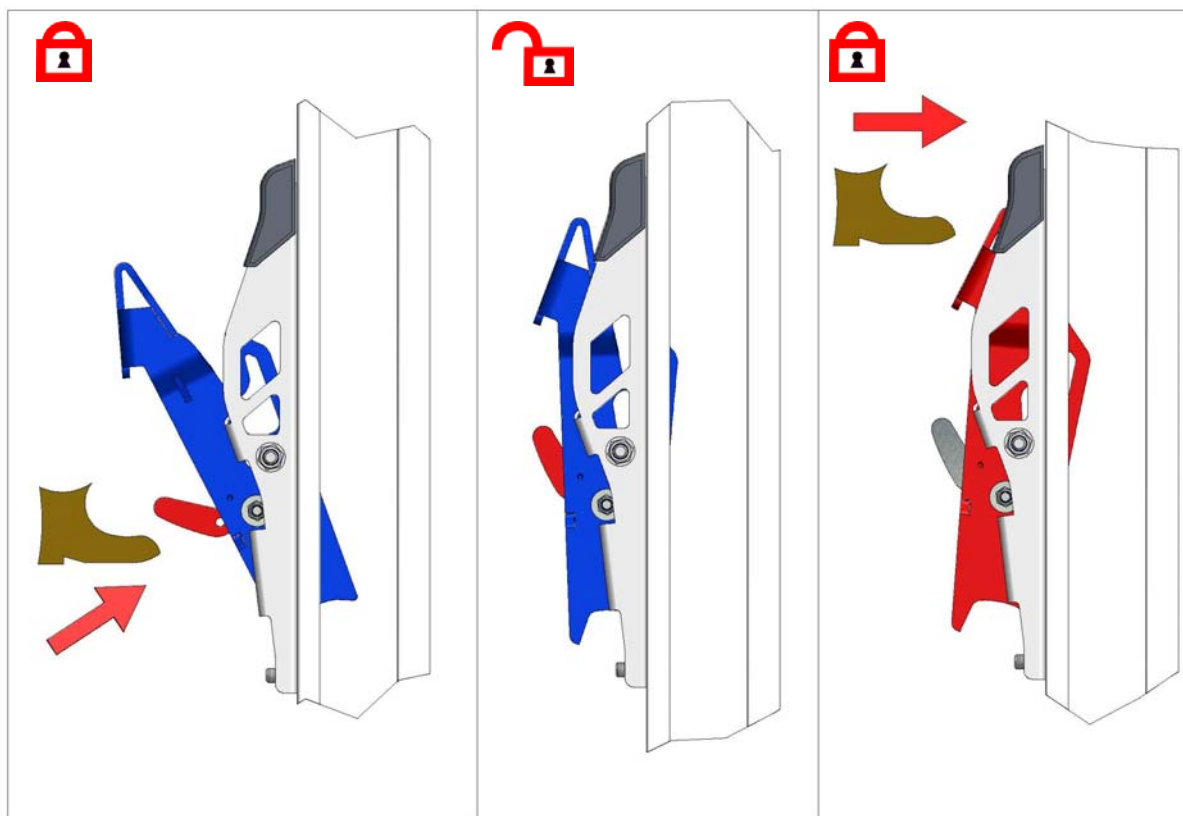



Figure 20, Engaging and Disengaging Locking Catch

	<p>CAUTION: For safety, the chain must be secured using the chain keep to prevent the door dropping in the event of a spring failure.</p>
---	--

- Windspeed over 32kph / 20mph

	<p>ATTENTION: It is vital that a closed door is secured via the locking catches when the wind speed is above 32kph / 20mph</p>
---	---

From Open: If the Locking catch (J1) is disabled push on the top section of the locking plate for re-activation (Figure 21i). Pull on the outer chain to close your door and when the bottom tube passes the locking catch (Figure 21ii) backwind the door until the bottom tube engages with the Locking Catch, continue to operate the chain to tension the sheet until no more movement is available (Figure 21iii). Insert both chains into the chain keep.

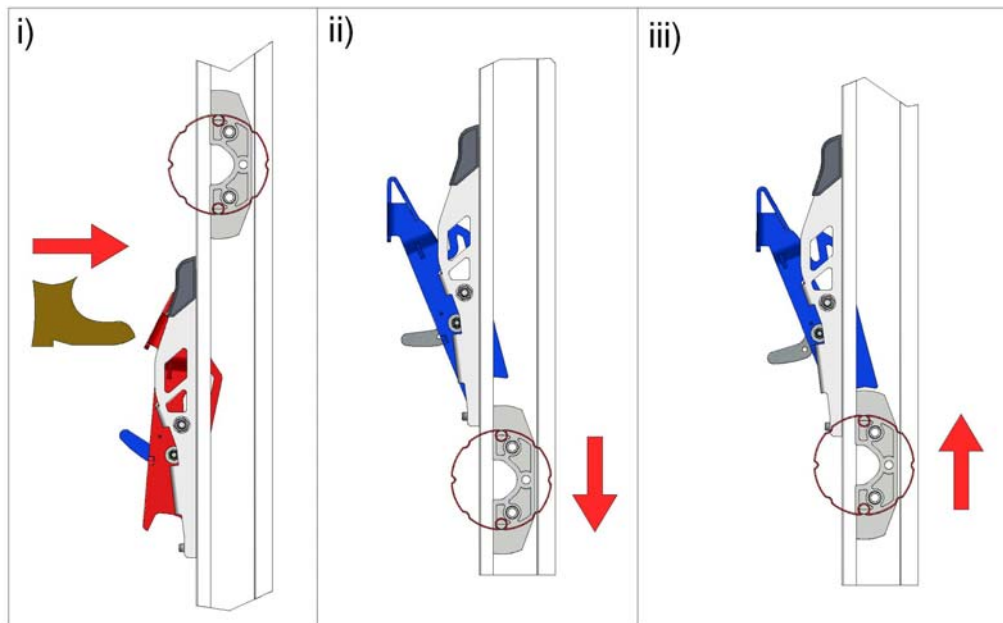

Figure 21, Locking Door Closed

From Closed: Pull on the outer chain to lower the door at least 10mm, open both Locking Catches by pushing on the top section of the locking plate (Figure 22). Pull on the inner chain to fully open the door and insert both chains into the chain keep.

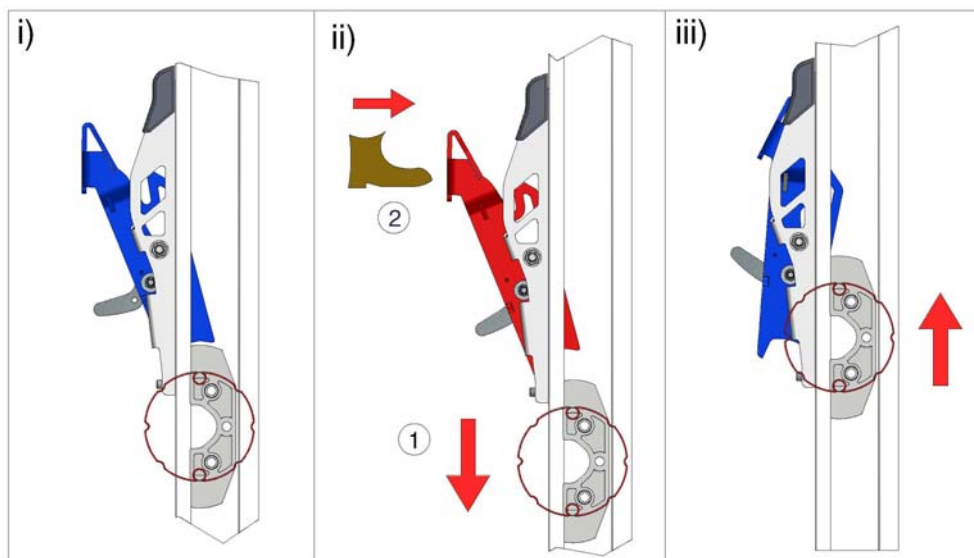

Figure 22, Opening Door from Locked Position



CAUTION: The chain must be secured using the chain keep to prevent the door movement.

Important Safety Information

ENG

- This door must only be operated by users familiar with its operation.
- When operating the door do not place fingers near the guide rails or other moving parts at any time.
- Do not permit children to play with the door.
- Do not modify or attach any objects to the door as this may cause damage and/or injury.
- Operate the door only when properly adjusted and free from obstructions.
- Should the door become difficult to operate or inoperable, consult your local dealer. Repairs should only be carried out by competent personnel.

Maintenance of your door

- Check annually for corrosion of the supporting bolts fixing the product to the building, the bolt holding the shaft into the top brackets and the blind in general. Replace suspect items to ensure it is safe for operators and bystanders alike
- The spring has a design life of 10,000 operations, which equates to using the door approximately 3 times a day for 10 years. After 10 years we recommend a replacement spring be fitted, or following the dismantling instructions given below remove the spring annually to ensure it has not broken.
- Annually clean the magnet on the locking catches to remove surface dirt.
- Should Screen material be damaged, repair with special repair kit (code SPS-99) available from your Galebreaker dealer, importer or head office.

How to dismantle your door

Follow the installation instructions in reverse order. In particular ensure all spring tension is removed before unbolting the top brackets to remove the roller assembly and recoil spring.



CAUTION: To prevent injury ensure spring has no residual tension before removal.

NOTE: This product has been tested to European Standard EN 12424 with a Resistance to Wind Load rating of Class 5. Tried and tested in the harshest weather conditions, a summary of our guarantee is as follows, see our website for full details:

- **Mechanical components:** 100% guarantee for two years, followed by an eight year graduated guarantee.
- **Electrical components:** 100% guarantee for two years, followed by a three year graduated guarantee.

ENG

RAIN INGRESS: Please note that in extreme weather conditions some moisture will penetrate a mesh material.

Wind Load Resistance:

Mesh 75% Solid

Up to 25sqm = Class 5

Solid Material

Up to 25sqm = Class 5

Up to 36sqm = Class 4

RIGHTHAND TO LEFTHAND SPRING CONVERSION

RH = Drive bracket on the right with spring bracket on left

For LH to RH conversion, follow instructions in reverse order

ENG

